



Modification:		Date:	
Review:		Date:	
Approve:		Date:	

### Revision History

Version	Date	Content Change	Modification	Review	Approve
V1.0	2019-09-20	First edition			
V1.2	2019-12-20	Parameter adjustment and modification of function description			
V2.0	2020-03-05	Size changes on master board and restrictor			

### Content

1、	Product Overview .....	Error! Bookmark not defined.
2、	Basic Features.....	- 5 -
3、	Functional Diagram: .....	- 6 -
4、	Ambient Requirements .....	Error! Bookmark not defined.
5、	Parameter Description (All parameters can be modified by software)	Error! Bookmark not defined.
6、	Protection Board Interface Definition .....	Error! Bookmark not defined.

1.Electrical Interface Definition: .....**Error! Bookmark not defined.**

2.RS232 Communication Port Definition: .....- 18 -

3.RS485-1/CAN Communication Interface Definition: .....- 19 -

4.RS485-2 Communication Interface Definition: .....- 20 -

7、 Functional Operation Instructions..... Error! Bookmark not defined.

1.LED Indicators .....- 22 -

2.DIP Switch Setting: .....- 24 -

3.Dry Contact Output: .....- 24 -

4.Key Operation .....**Error! Bookmark not defined.**

5.Buzzer Action.....- 25 -

6.Sleep Function .....**Error! Bookmark not defined.**

7.Wake-up Function .....- 26 -

8Current Limiting Function .....**Error! Bookmark not defined.**

9.Heating Function .....- 26 -

8、 Communication Instructions..... Error! Bookmark not defined.

1. RS232 Data Upload & Parameter Settings .....- 27 -

2.CAN Communication Software Upgrade and Inverter Communication**Error! Bookmark not defined.**

3.RS485-1 Communication & Inverter or EMS communication .....- 27 -

4.RS485-2 Data Upload & Cascading Capabilities .....- 28 -

5.Parallel (Cascading) Function of Battery Packs.....- 28 -

9、 Computer Software..... Error! Bookmark not defined.

10、 Communication Protocol..... Error! Bookmark not defined.

11、 Protection Board Size Specs (Unit: mm) .....- 31 -

12、 Protection Board Operation Precautions Error! Bookmark not defined.

## 1 Product overview

This protection board is an intelligent battery management system designed for 16 strings or less (6S-16S) lithium battery backup power supply or energy storage battery, it adopts modular design and integrates together functions such as collection, monitoring, management and communication. It supports up to 16 channels of single voltage acquisition, 1-channel high-precision current acquisition, 6-channel temperature acquisition, maximum continuous 100A charging and discharging current, it equips with intelligent charging equalization, SOC power estimation, data storage, 10A current limiting module, LED display, charging and heating (reserved) 、 pre-discharge (pre-charge), RS232 communication, CAN communication and RS485 communication functions.

## 2 Basic Features

- Cell over-charge, Cell over-discharge, total pressure over-voltage, total pressure under-voltage, over-current, high temperature, low temperature and other alarm and protection functions.
- Short circuit protection function.
- Intelligent charging equalization management function (passive equalization)
- Provide one channel of isolated RS232 communication, complying with YD/T1363.3 communication specification.
- Provide one channel of isolated RS485 communication (2 RJ45 ports in parallel), complying with YD/T1363.3 communication specification, implement communication cascade.
- Provide one isolated CAN interface and inverter communication (communication protocol can be specified).
- Provide an isolated RS485 interface and inverter communication or EMS communication (communication protocol can be specified).
- Support RS232 communication to connect with the host computer, and to monitor the status of the battery pack and set battery pack parameters in real time.
- Support system communication cascade, implement multi-group battery parallel monitoring and management function through RS232/RS485

communication with host computer software.

- Provide LED status indication function (capacity and alarm).
- Provide buzzer alarm function.
- Provide one channel dry contact output function.
- Provide 10A charging current limiting function (triggering conditions can be set for current limiting).
- Provide multi-function buttons to achieve reset, sleep, wake-up functions.
- Various parameters can be set and capacity self-learning function.
- Provide standby sleep function, the system maintains low power consumption in non-working mode.
- Support RTC and data storage function, can read the system history record through the host computer.
- Provide pre-charge function, At booting stage, it prevents high current impact and malfunction to protect the device.
- Provide self-check function, it can check whether the MOS tube, cell, NTC temperature, sampling and storage functions are normal.
- Support CAN software firmware upgrade function.
- High-precision voltage sampling ( $\leq 10\text{mV}$ ).
- High-precision current sampling ( $\cong 2\%@\text{FS}$ ).
- 6-channel temperature sampling ( $\leq 3^\circ\text{C}$ ).

#### 一、 Functional diagram:

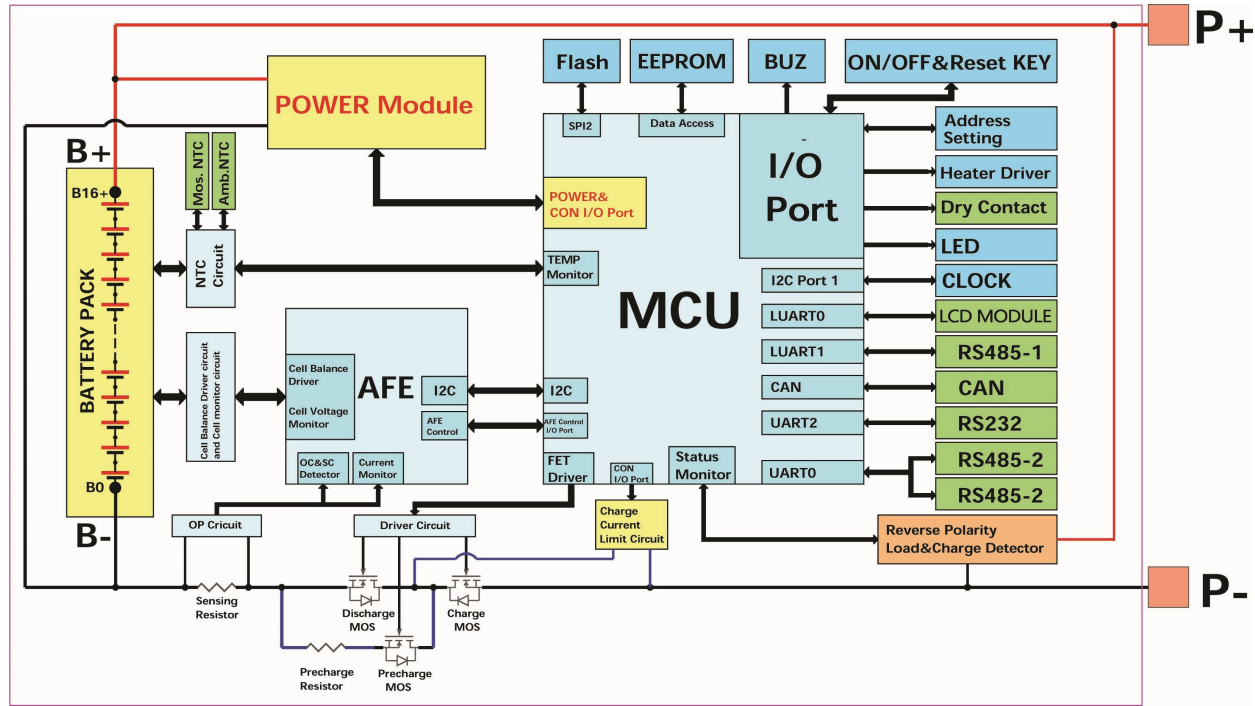

二、 Ambient requirements

Feature	Range	Typical Value	Unit
Input Voltage	20-80	52	V
Operating Temperature	-20~75	25	°C
Operating Humidity	5-85%	/	%RH
Storage Temperature Range	-20~75	25	°C
Storage Humidity Range	5-85%	/	%RH

三、 Parameter Description ([All parameters can be modified by Master PC Software which is downloaded from our official website:www.cleverbms.com](http://www.cleverbms.com); Let me take Lifepo4 battery 48V 100AH for example)

Index	Feature	Details	Standard
1	Over-charge Alarm	Cell over-charge alarm voltage	$3550 \pm 10$ mV
		Overall over-charge alarm voltage	$56000 \pm 200$ mV
2	Over-charge Protection	Cell over-charge detection voltage	$3650 \pm 10$ mV
		Cell over-charge detection delay time	1000mS×3 次
		Cell over-charge release voltage	$3450 \pm 10$ mV
		Overall over-charge detection voltage	$57600 \pm 200$ mV
		Overall over-charge detection delay time	1000mS×3 次
		Overall over-charge release voltage	$54400 \pm 200$ mV
		Over-charge capacity release	SOC<90%
3	Over-discharge Alarm	Cell over-discharge alarm voltage	$2700 \pm 10$ mV
		Overall over-discharge alarm voltage	$44000 \pm 200$ mV
4	Over-discharge Protection	Cell over-discharge detection voltage	$2600 \pm 10$ mV
		Cell over-discharge detection delay time	2000mS×3 次
		Over-discharge release voltage	$2950 \pm 10$ mV
		Overall over-discharge detection voltage	$42400 \pm 200$ mV
		Overall over-discharge detection delay time	2000mS×3 次



		Overall over-discharge release voltage	$48000 \pm 200\text{mV}$
5	Over-current Alarm	Charge over-current alarm current	$105 \pm 1\text{A}$
		Discharge over-current alarm current	$105 \pm 1\text{A}$
6	Over-current Protection	Discharge over-current protection current 1	$115 \pm 1\text{A}$
		Discharge over-current detection delay time 1	1S
		Discharge over-current protection current 2	$125 \pm 5\text{A}$
		Discharge over-current detection delay time 2	100ms
		Discharge over-current protection release condition	60S (adjustable) protection release after over-current protection, lock after 3 consecutive times within 5 minutes, need manual restart
		Charge over-current protection current	$110 \pm 1\text{A}$
		Charge over-current detection delay time	$2 \pm 1\text{ S}$
7	Short Circuit Protection	Protection conditions	500A (Test with $0.1\Omega$ resistance in series)
		Detection delay time	$\leq 350\mu\text{S}$

		Protection release conditions	1. 60S auto release/lock after 3 consecutive times within 5 minutes 2. Charging current > 1A
8	Temperature Protection	MOS High temperature alarm condition	90°C ± 3°C
		MOS High temperature protection conditions	115°C ± 3°C
		MOS High temperature protection recovery conditions	50°C ± 3°C
		Charge w/ high temperature alarm condition	50°C ± 3°C
		Charge w/ high temperature protection conditions	65°C ± 3°C
		Charge w/ high temperature protection recovery conditions	55°C ± 3°C
		Charge w/ Low Temperature Alarm Condition	0°C ± 3°C
		Charge w/ low temperature protection conditions	-10°C ± 3°C
		Charge w/ Cryogenic Protection Recovery Conditions	-1°C ± 3°C
		Discharge w/ high temperature alarm condition	50°C ± 3°C
		Discharge w/ high temperature protection conditions	65°C ± 3°C

		Discharge w/ high temperature protection recovery conditions	$60^{\circ}\text{C} \pm 3^{\circ}\text{C}$
		Discharge w/ low temperature alarm condition	$0^{\circ}\text{C} \pm 3^{\circ}\text{C}$
		Discharge w/ low temperature protection conditions	$-20^{\circ}\text{C} \pm 3^{\circ}\text{C}$
		Discharge w/ low temperature protection recovery conditions	$-10^{\circ}\text{C} \pm 3^{\circ}\text{C}$
		Ambient high temperature alarm condition	$60^{\circ}\text{C} \pm 3^{\circ}\text{C}$
		Ambient high temperature protection conditions	$70^{\circ}\text{C} \pm 3^{\circ}\text{C}$
		Ambient high temperature protection recovery conditions	$50^{\circ}\text{C} \pm 3^{\circ}\text{C}$
		Ambient low temperature alarm condition	$-10^{\circ}\text{C} \pm 3^{\circ}\text{C}$
		Ambient low temperature protection conditions	$-20^{\circ}\text{C} \pm 3^{\circ}\text{C}$
		Ambient cryoprotection recovery conditions	$-0^{\circ}\text{C} \pm 3^{\circ}\text{C}$
9	Charge Equalization	Balanced turn-on voltage	$3400 \pm 10 \text{ mV}$
		Balanced turn-on voltage difference	$50 \pm 10 \text{ mV}$
		Balanced turn-off voltage difference	$20 \pm 10 \text{ mV}$
		Equilibrium high temperature prohibition	$55 \pm 3^{\circ}\text{C}$
		Equilibrium low temperature prohibition	$-10 \pm 3^{\circ}\text{C}$

		Balance current	$80 \pm 20$ mA
10	Cell Voltage Difference Alarm	Cell voltage difference alarm voltage	500mV
	Cell Voltage Difference Protection	Cell voltage difference protection voltage	800mV
		Cell voltage difference detection delay time	2000mS
		Cell voltage difference release voltage	300mV
11	Capacity Default Setting	Design capacity	100 AH
		Low battery warning	SOC<5% (No warning on Charging)
12	Default Charge and Discharge Current	Charging current	100A
		Discharging current	100A
		Charging current limiting	10A ( continuous current flow )
13	Current Sampling Accuracy	Low current detection accuracy	Accuracy of $\pm 0.5$ A at 0-20A
		High current detection accuracy	21-100A 50%Range $\leq 2\%$
14	Isolated 232 Communications	One channel	Default baud rate 9600bps
15	Isolated 485 Communications	Independent 2 channels	Default baud rate 9600bps

16	Isolated CAN communication	One channel	Standard frame, default baud rate 500kbps
17	Dry Contact Output	One channel	Maximum 30VDC 1A current output
18	Electric Heating	One channel	Maximum load capacity 150W (48V 3A)
		Heating startup temperature	0°C ± 3°C
		Heating turnoff temperature	15°C ± 3°C
19	Pre-discharge (pre-charge) design current	The pre-charging resistance value and pre-charging time can be adjusted according to the actual load (the default pre-charging resistance is 28Ω/10W, and the default time is 5S)	The pre-charging time can be set. Before the discharging MOS is turned on (during power-on or protection recovery), start up the pre-charging circuit first and then switch to the normal charge and discharge MOS tube control.

20	Current Limiting Startup Current	Can be set	After the default charging current is greater than 30A, the current limiting mode is activated. After entering the current limiting mode, the current is checked every 10 minutes. If the current is less than the current limiting value, the current limiting board is turned off.
21	Sleep	Sleep voltage	2500mV
		Sleep delay time	5min
22	Resistance	Main circuit connecting resistance	$\leq 5\text{m}\Omega$
23	Power Consumption	Current consumption during operation	$\leq 30\text{mA}$
		Sleep mode current consumption	$\leq 100\ \mu\text{A}$

The following parameters are tested in 25 degree environment, unless otherwise specified.

#### 四：The Protection Board Interface Definition

##### Electrical Interface Definition:

充电机和负载： Charger & load

电池组: Battery

电压采集线: Voltage Collection Line

电芯温度采集线: Cell Temperature

液晶显示器接口: LCD Display Interface

电加热: Electric Heating

充电机握手端口: Charger Handshake Port

冷压端子: Cold-Press Terminal

电量指示灯: Battery Capacity Indicator

拨码开关地址码: DIP Switch Address

干接点: Dry Contact

复位键: Reset

Charger and Load  
**充电机和负载P-**

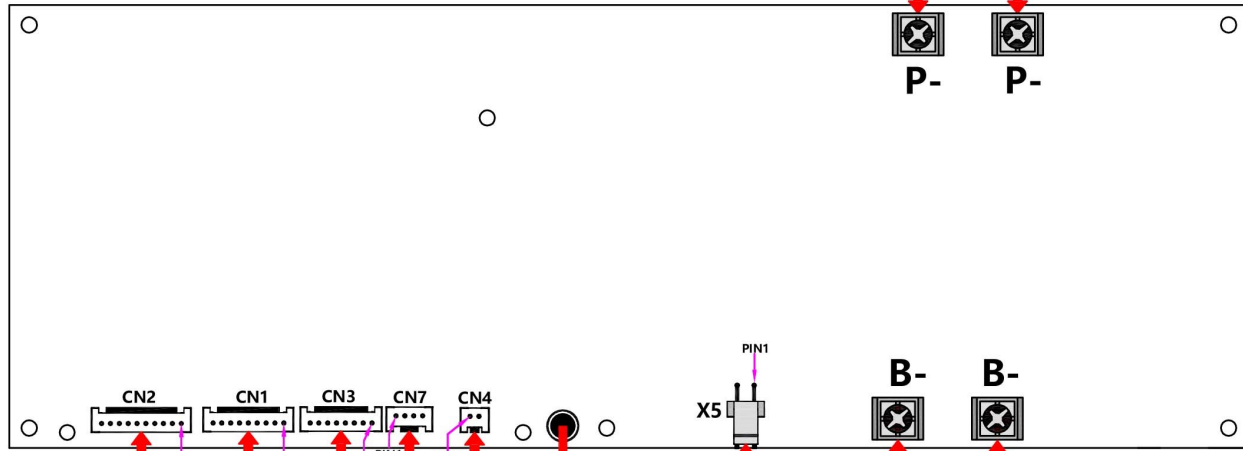

PORT CN1 AND CN2 IS FOR BALANCING WIRES  
 AND PORT CN3 IS FOR NTC\*4

Negative of entire battery pack

Positive of entire battery pack

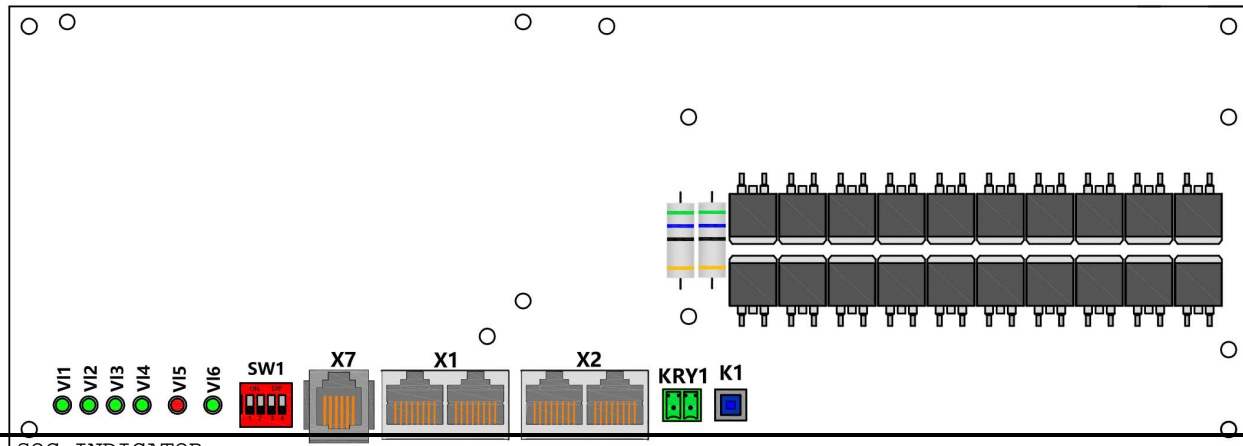

SOC INDICATOR  
 电量指示灯 绿色  
 电量指示灯 红色  
 电量指示灯 绿色  
 电量指示灯 红色  
 地址码  
 拨码开关  
 RS232  
 RS485-1 CAN  
 RS485-2  
 干接点  
 复位键

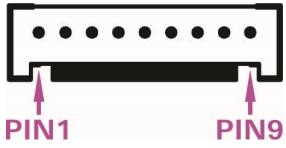
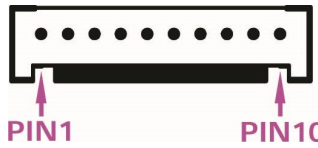

**Control Board Port Position Definition Diagram**

Interface	Definition Description	
B+	BMS Power supply terminal, connect to battery pack B+ (head positive)	
B-	Connect to battery pack B- (head negative)	
P-	Connect to charger or negative terminal of the load (P-)	
<p>CN1 (1#) Cell voltage detection interface 1</p> 	Interface	Definition
	CN1-1	B0 (black wire goes to negative of 1st cell)
	CN1-2	B1+
	CN1-3	B2+
	CN1-4	B3+
	CN1-5	B4+
	CN1-6	B5+
	CN1-7	B6+
	CN1-8	B7+
	CN1-9	B8+
<p>CN2 (2#) Cell voltage detection interface 2</p> 	Interface	Definition
	CN2-1	B9- (black line)
	CN2-2	B9+
	CN2-3	B10+
	CN2-4	B11+
	CN2-5	B12+
	CN2-6	B13+
	CN2-7	B14+

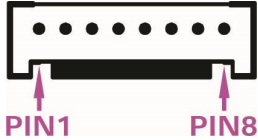
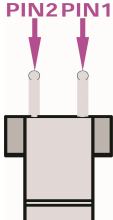
	CN2-8	B15+
	CN2-9	B16+ <small>(wire B 16 and wire B15 shall be combined together and shorted when you use BMS 16S as BMS 15S)</small>
	CN2-10	NC (Hanging)
<p>CN3 Cell temperature detection interface</p> 	Interface	Definition
	CN3-1	NTC1+
	CN3-2	NTC1-
	CN3-3	NTC2+
	CN3-4	NTC2-
	CN3-5	NTC3+
	CN3-6	NTC3-
	CN3-7	NTC4+
	CN3-8	NTC4-
<p>X5 Electric heating socket (reserved)</p> 	Interface	Definition
	X5-1	HEAT (Heating control positive terminal)
	X5-2	P-(Heating control negative terminal)

- Note: The charger or positive terminal of the load is directly connected to the B+ of the battery pack
- RS232 Communication Port Definition:

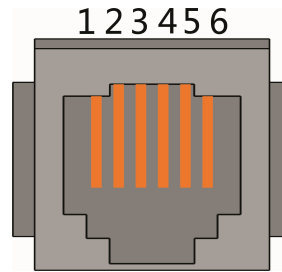

X7(RJ12) Port

interface	Definition description	
<p style="text-align: center;"><b>X7</b></p> <p>Communication port definition</p>	PIN 1	NC (void)
	PIN 2	NC (void)
	PIN 3	TX The protection board sends data (the data pin for host computer)
	PIN 4	RX The protection board receives data (host computer sends data)
	PIN 5	Ground Signal Ground
	PIN 6	NC (void)

### 3. RS485-1/CAN Communication interface definition:

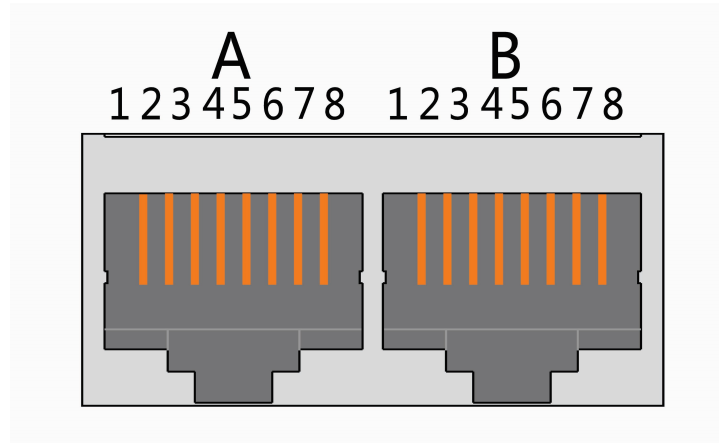

X1(dual RJ45) Port

Interface	Definition Description		Definition Description			
<p style="text-align: center;"><b>X1</b> Communicati on port definition</p>	<p style="text-align: center;"><b>Part A</b> CAN Port</p>	PIN 1	CANL	<p style="text-align: center;"><b>Part B</b> RS-485-1 Port</p>	PIN 1	RS485-B1
		PIN 2	CGND		PIN 2	RS485-A1
		PIN 3	NC (void)		PIN 3	RS485-GND
		PIN 4	CANH		PIN 4	RS485-B1
		PIN 5	CANL		PIN 5	RS485-A1
		PIN 6	NC (void)		PIN 6	RS485-GND
		PIN 7	CGND		PIN 7	NC (void)
		PIN 8	CANH		PIN 8	NC (void)

4. RS485-2 Communication interface definition:

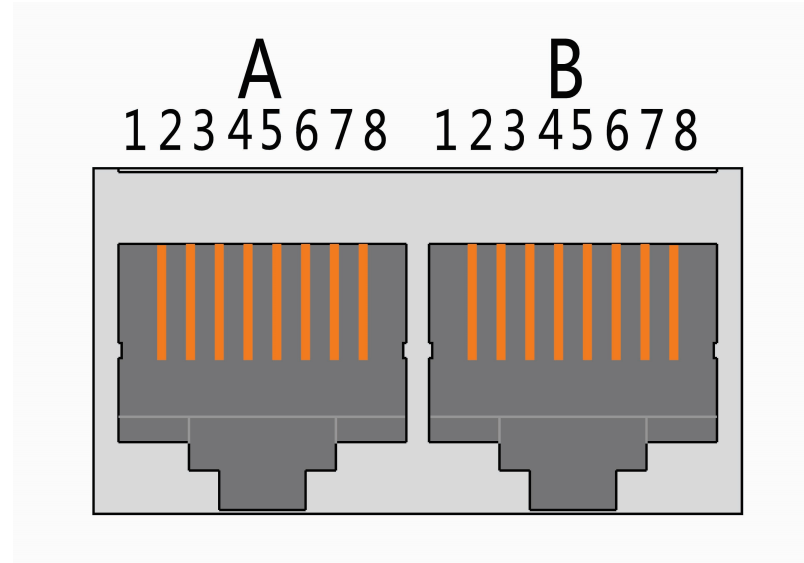

X2(dual RJ45) Port

Interface	Definition Description		Definition Description			
<p align="center"><b>X2</b> Communicati on port definition</p>	<p align="center"><b>Part A</b> RS-485-2 Port</p>	PIN 1	RS485-B2	<p align="center"><b>Part B</b> RS-485-2 Port</p>	PIN 1	RS485-B2
		PIN 2	RS485-A2		PIN 2	RS485-A2
		PIN 3	RS485-GND		PIN 3	RS485-GND
		PIN 4	NC (void)		PIN 4	NC (void)
		PIN 5	NC (void)		PIN 5	NC (void)
		PIN 6	RS485-GND		PIN 6	RS485-GND
		PIN 7	RS485-A2		PIN 7	RS485-A2
		PIN 8	RS485-B2		PIN 8	RS485-B2

## 7 Functional Operation Instructions

### 1. LED Indicator Description

- LED Working Status

Status	Normal/Alarm, Protect	running light	Alarm Light	Battery Capacity Indicator				Description
		Green	Red	Green L4	Green L3	Green L2	Green L1	
Off	Sleep	Off	Off	Off	Off	Off	Off	All Off
Standby	Normal	Flash1	Off	Display according to battery capacity, Read the following table for battery capacity indications				Standby
	Alarm	Flash1	Flash3					Low battery
Charging	Normal	Always On	Off	Read the following table for battery capacity indications				Alarm when over-voltage, Light off
	Alarm	Always On	Flash3					
	Overcharge Protection	Always On	Off	On	On	On	On	If the charger is not connected, the indicator light is the same as the power standby state
	Temperature, Over-current Protection	OFF	Always On	Off	Off	Off	Off	Turn off charging

Discharging	Normal	Flash3	Off	Read the following table for battery capacity indications				
	Alarm	Flash3	Flash3					
	Over-discharge protection	off	Off	Off	Off	Off	Off	turn off discharge
	temperature, overcurrent short circuit protection	off	On	Off	Off	Off	Off	turn off discharge
Invalid		Off	On	Off	Off	Off	Off	Turn off charge and discharge

● LED Flash Description:

Flashing Type	On	Off
Flash1	0.25S	3.75S
Flash2	0.5S	0.5S
Flash3	0.5S	1.5S

● Battery Capacity Description:

Status		Charging				Discharging			
Battery Indicator		L4	L3	L2	L1	L4	L3	L2	L1
Capacity (%)	1~25%	Off	Off	Off	閃2	Off	Off	Off	On
	25~50%	Off	Off	Flash2	On	Off	Off	On	On
	50~75%	Off	Flash2	On	On	Off	On	On	On
	75~100%	Flash2	On	On	On	On	On	On	On

● On-Off Switch Indicator Light:

<b>On</b>	The LED indicators light up from the lowest capacity indicator (VL1) and light up in sequence in every 0.5s, all light up till the end of pre-charging
-----------	--

Off	the LED indicators light up at the same time, after 1.5s, then starting from the lowest capacity indicator (VL1), all light up in sequence in every 0.5s
-----	--

**2. DIP Switch Setting:**

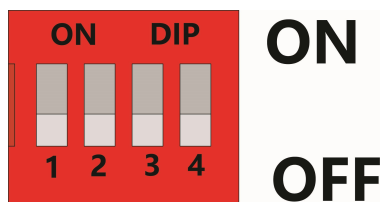

**DIP Switch Diagram (SW1 Interface)**

➤ The coding switch is used to set the address of each BMS protection board, the value is 1 at position ON, 0 at position OFF, the master board address is 0, slave board address is 1~15.

➤ DIP address table as following:

position	address				position	address				position	address				position	address				
	1	2	3	4		1	2	3	4		1	2	3	4		1	2	3	4	1
0	0	0	0	0	1	0	0	1	0	5	0	0	0	1	9	0	0	1	1	13
1	0	0	0	0	2	1	0	1	0	6	1	0	0	1	10	1	0	1	1	14
0	1	0	0	0	3	0	1	1	0	7	0	1	0	1	11	0	1	1	1	15
1	1	0	0	0	4	1	1	1	0	8	1	1	0	1	12	1	1	1	1	16

**KRY1 (2EDG-3.81-2P) Interface**



This protection board can provide one channel of dry contact signal, all dry contact signals are passive switches, regardless of polarity;

KRY1 (2P Terminals)		
BMS Status	Operation	Note
BMS Normal	1/2 pin is disconnected	
BMS at Protection	1/2 pin is connected	SOC alarm, under-voltage and over-voltage alarm and output when BMS in protection state, such as under-voltage protection, over-voltage protection or short-circuit protection;

#### 4. Key operation instruction

- When the BMS is in sleep state, press the button for more than 1s, the protection board is activated.
- When the BMS is in working state, after the button is pressed for more than 3s and less than 6s, the BMS enters the sleep state.
- 5. When the BMS is in working state, after the button is pressed for more than 6s, the protection board is reset.

#### 5. Buzzer actions

- Power on state, the Buzzer performs a long beep;
- Power sleep state, the Buzzer performs short beep;
- Short-circuit protection, Buzzer beeps every 2s, the Buzzer stops beeping after locking on short-circuit protection 3 times.

The buzzer function can be enabled or disabled through host computer, and the factory default is disabled;

When buzzer function is disabled, the buzzer does not work at the time of protection board alarming and protection (except

short-circuit and reverse polarity protection).

## 6. Sleep Function Description

In order to reduce the power consumption of the whole system, the system has a sleep function. The system will enter into sleep mode when the following conditions are met:

- 1) The cell over-discharge protection has not been released for 5 minutes (the time is customizable) .
- 2) The standby state reaches 24 hours (no communication, no charge and discharge, no charger access).
- 3) Operate the composite key switch according to the operating rules.
- 4) The protection board can be forced to shut down and enter the sleep mode by operating host computer' s "forced sleep" button

## 7 Wake-up Function

Combined with the actual situations, for the convenient usage, the system provides a variety of wake-up methods:

- 1) Wake up from charging: the charger voltage is greater than 36V when connecting to the charger
- 2) Wake up by pressing keys
- 3) Wake up via communication, which is wake-up via RS485-1, RS232 serial port and CAN communication;

Please note that the battery cannot be woken up by the serial ports while it is in sleep mode due to cell or overall over-discharge.

## 8 Current Limiting Function

The protection board can limit current while charging, the maximum charging current is  $10\pm 1$  A, end user can set the condition to trigger current limiting function and enable/disable the function through software in host computer.

The default triggering condition of the current limiting is that the charging current is greater than 30A. Entering the current limiting mode, it will

check current every 10 minutes. when the current is less than the current limiting triggering value, the current limiting function will be turned off.

When the current is greater than the current limiting triggering value, then the system will stay in sleep mode.

### **9 Heating Function\* (Reserved)**

The protection board can control charging and heating, and the BMS monitors the temperature of the cells in real time (4 pieces). heating function of the protection board is activated when the minimum cell temperature is lower than the heating-on temperature, Heating membrane will be closed when the temperature of all cells reaches the heating-off temperature.

The maximum output current of the heating function is 3A, which mean, the maximum load capacity is 150W at 48V.

## **四、 Communication**

### **1. RS232 Data Upload & Parameter Settings**

BMS provides RS232 communication function to upload data for battery pack and parameters can be customized, the default baud rate is 9600bps, and the RS232 communication interface is RJ12 network port.

It can communicate with host computer through the RS232 port, can monitor the status and information of the battery pack in real time, and can re-modify and set the parameters of the protection board.

### **2. CAN communication Software Upgrade and Communication Function of inverter**

The BMS provides mutual communication for the battery pack and the inverter to exchange data via CAN communication, the default baud rate is 500Kbps, and the CAN communication interface is the RJ45 network port.

The BMS has the CAN communication function for software upgrade. The default baud rate is 500Kbps. The BMS can be updated and upgraded through host computer software.

### **3. RS485-1 communication and communication function of inverter or EMS**

The BMS provides mutual communication for the battery pack and the inverter to exchange data via CAN communication, The default baud rate is 9600bps, and the RS485-1 communication interface is the RJ45 network port.

BMS provides RS485 communication function with network management system (EMS), the default baud rate is 9600bps

#### **4 RS485-2 Data upload and cascading function**

BMS provides RS485 communication function for uploading data of battery packs, it also provides RS485 uplink and cascade communication function. The default baud rate is 9600bps, and the RS485-2 communication interface is dual RJ45 network ports. Through the RS485-2 port, BMS can communicate with host computer, the status and information of the battery pack can be read and monitored in real time. (Parameters cannot be modified in RS485 communication)

#### **5 Parallel (cascading) function of battery packs**

When the battery packs are cascaded, the one with the communication address 0001 is called the master battery pack, and the rest with other communication address are called the slave battery packs. The slave battery pack can communicate with the master battery pack through the RS485 communication interface, and the master battery pack centrally packs and manages the data for each battery pack in the cascaded system.

When the battery packs are cascaded, only the master battery pack can communicate with the host computer, uploading the data, status and other information of all battery packs in the cascaded system, achieving remote monitoring by combing monitoring and management.

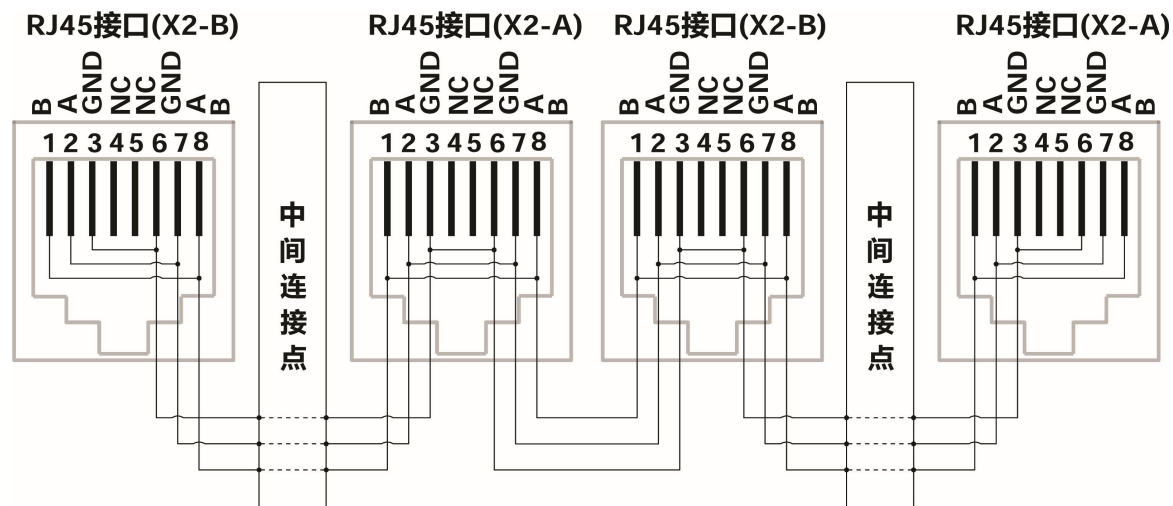



RS485 Parallel wiring diagram

接口: Interface

中间连接点: intermediate connection point

When performing multi-machine parallel communication operation, it is necessary to configure the DIP address of each PACK first. The DIP code is in BCD format.

Address 1 is defined as  (black dot for OFF status, while for ON status, same as below) , Address 2 is defined as  ,

address 3 is defined as  , this applies to other addresses.

## 5 Computer Software

- Computer software model is “BMS monitoring software V5.5” 。
- You can read the operating status of the protection board such as voltage, current, temperature, alarm and protection through the host computer software, set the parameters of the BMS, view the historical records of the protection board, and open the function module of the BMS.
- For specific operations, please refer to “BMS PC Software Operation Manual”

## 10 Communication protocol description

### ● RS232 Protocol

The communication protocol complies with the “Q/ZTT 2227-2017 Integration Technical Requirements for Cascade Lithium Iron Phosphate Batteries used in Base Stations”, and some of the contents have been modified in combination with the company’s specific requirements to meet the requirements for accessing the master and slave computers.

### ● RS485-2 Protocol

The communication protocol complies with the “Q/ZTT 2227-2017 Integration Technical Requirements for Cascade Lithium Iron Phosphate Batteries used in Base Stations”, and some of the contents have been modified in combination with the company’s specific requirements to meet the requirements for accessing the master and slave computers.

### ● RS485-1 Protocol

Using isolated communication, it is customized by the inverter equipment manufacturer.

### ● CAN Protocol

Using isolated communication, it is customized by the inverter equipment manufacturer.

11 Protection Board Size Specs (unit: mm)

- Master control board Size: 280(L)x100(W)x50(H) (unit: mm)





电芯接口: Cell Interface

温度检测: temperature check

显示输出: output display

电量显示灯: Battery Compacity Indicator

拔码开关地址码: DIP switch address code

大电容: large capacitance

限流电源: Current limited power supply

安德森插端子: Anderson plug-in terminal

冷压端子: cold-press terminal

干接点: dry contact

复位键: Reset

未注公差: Unspecified tolerance

单位: unit

### 充电机和负载P-

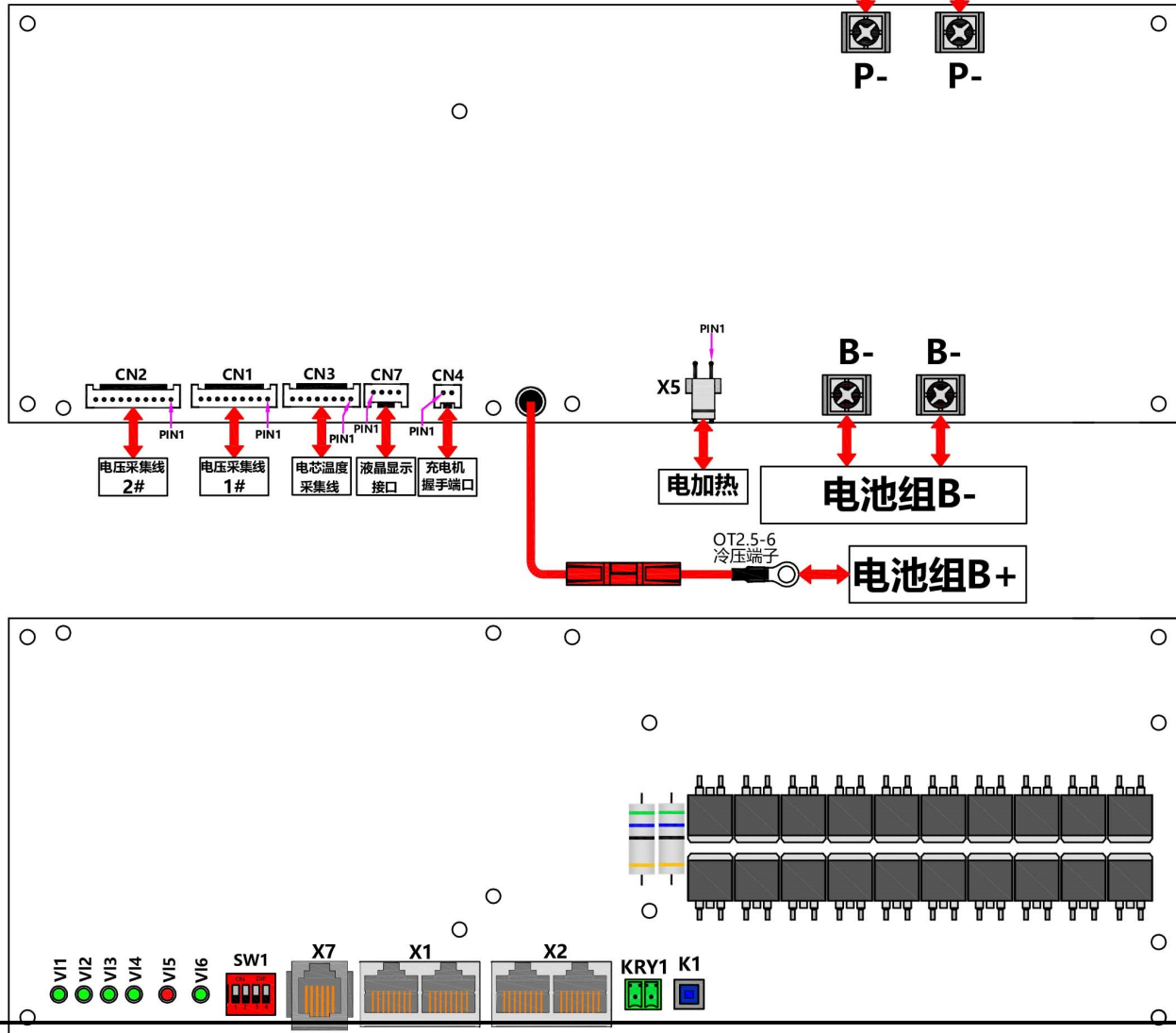

电量指示灯 绿色 红色 绿色 拨码开关 地址码  
 灯 灯 灯 地址码  
 RS232 RS485-1 CAN RS485-2 干接点 复位键

- Restrictor size: 142(L)x72(W)x25(H) (unit: mm)

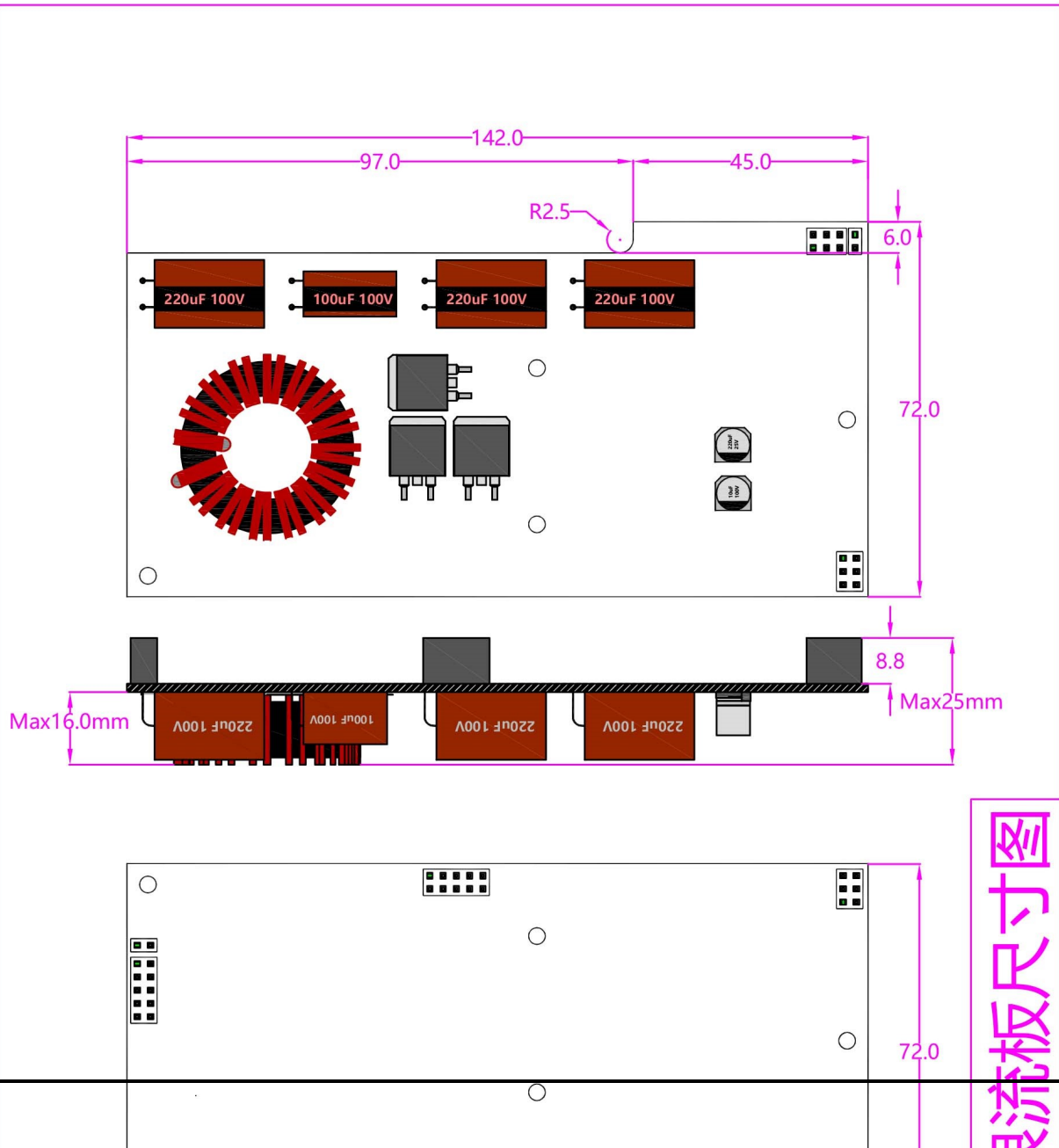

回流板尺寸图

## 12 Precautions for the operation of the protection board

### 1 Pay attention to static electricity during assembly and use

Do not touch the conductive parts of the protective board; If direct contact is necessary, the body should be well grounded or the static electricity of the body should be released; The soldering iron used for welding and the power tools used for assembly must be well grounded without leakage.

2 Avoid stress on the protection board during assembly and use, so as not to damage the electronic components and cause the failure of the circuit board.

3 In order to ensure that the BMS is not damaged during the installation process, it is required to follow the steps below:  
Connect first the B-line of the battery pack (head negative)  $\Rightarrow$  Connect to other external terminals such as temperature sampling line, LCD cable, communication line, etc.  $\Rightarrow$  Connect the battery sampling lines in sequence, from low to high  $\Rightarrow$  Finally, connect the B+ line of the BMS power supply terminal.

**NOTE: When removing the BMS, follow the reverse order above.**

4 Please follow the design parameters and conditions of use in production, and must not exceed the values in this specification, otherwise the protection board could be damaged.

5 Soldering: The temperature of the soldering iron tip is less than 280 degrees; the time for soldering the same device does not exceed 10s; do not use acid flux.

6 Storage: If the battery pack is stored for a long time, due to the static current of the protection board and the self-discharge of the battery, the battery pack needs to be charged regularly; Pay attention to waterproof and moisture-proof of the system.

- 7 Pay attention to anti-static current, waterproof, moisture-proof, avoid extrusion, collision, etc. during transportation, so as not to damage the protection board.
- 8 Maintenance: When the protection board is faulty, professional personnel should be invited to detect and maintain.